

CE-531NZ CE-531NZSB

CE
UL AWM 2587

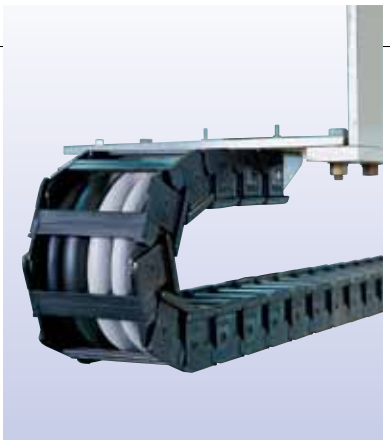
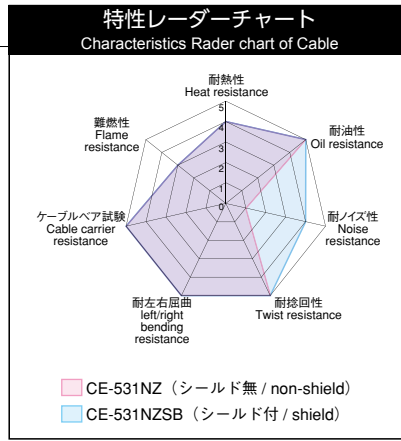

用途 / Use

- ケーブルベア、ロボットへの配線
Wiring to cable carriers and robots
- 油環境下での配線
Wiring in oil environment
- 耐ノイズ性要求箇所への配線 (シールド付タイプ: CE-531NZSB)
Wiring to the portion requiring noise resistance (Shielded type: CE-531NZSB)

特長 / Features

- CE&UL・cUL&<PS>E (0.75 ~ 2.5mm) &TR-CU グローバルスタンダードケーブル
Global-standard cables designed to CE, UL, cUL, <PS>E (0.75-2.5mm) and TR-CU
- 耐ノイズ性 (シールド付タイプ: CE-531NZSB)
Noise resistance (Shielded type: CE-531NZSB)
- 耐油・耐熱 (105°C) ・柔軟・耐屈曲性 可動用
Oil resistance, heat resistance (105°C), flexible, bending resistance, movable
- 素線径 0.08mm可とうより線 (中心補強紐入り)
Flexible 0.08mm wire strand (containing reinforcement cord at its center)

認証 / Approvals



※適用サイズが限定されます。テクニカルデータの“適用サイズ”をご参照ください。
The cable is subject to limitation of applicable sizes for each relevant standard. For details, refer to “Adaptation size” for each standard in [Technical data] given below.

使用温度範囲 / Temperature range

- 固定時 / Fixed : -30 ~ 90°C ※
 - 可動時 / Flexing : 0 ~ 90°C
- ※ 0°C以下でご使用の際は、衝撃・屈曲・振動等の外的力が加わらないようにしてください。
If you use it in temperature less than 0°C, you should be careful about shocks, flexure, vibration and so on.

曲げ半径 / Bending radius

- 固定時: ケーブル外径の4倍以上推奨
Fixed: 4 times or more of the cable diameter
- 可動時: ケーブル外径の7.5倍以上推奨
Flexing: 7.5 times or more of the cable diameter

RoHS 指令 / RoHS Directive

- 適合 / Conformity

テクニカルデータ / Technical data

ケーブルタイプ / Cable designation	CE		UL・cUL	<PS>E
	CE-531NZ MA-AA	CE-531NZSB MA-BB	AWM style 2587	VCTF
適用サイズ / Adaptation size	全サイズ / All Size		全サイズ / All Size	0.75 ~ 2.5 mm
定格電圧 / Voltage rating	300/500V		600V	300V
定格温度 / Temperature rating	70°C		90°C	75°C
試験電圧 / Test voltage	AC2000V・15min		AC3000V・1min	AC2000V・1min
難燃性 / Flame resistance	EN 60332-1-2		VW-1, FT1	60度傾斜 60° Angle
適用規格 / Adaptation standard	EN 50525-2-51 (HD 21.13) に準ずる VDE 0285-525-2-51 に準ずる		UL 758 CSA C22.2 No.210	電気用品安全法 Electrical Appliance and Material Safety Law

構造概略 / Construction

項目 / Item	品名 / Code	CE-531NZ	CE-531NZSB
導体 / Conductor		軟銅複合より線 (中心補強紐入り) / Rope-lay stranded of annealed copper (containing reinforcement cord at its center)	
絶縁体 / Insulation		耐熱性ビニル混合物 / Heat resistant PVC	
より合わせ / Assembly		線心を円形により合わせ / Circular	
テープ / Tape		5心以上はテープを重ね巻き / Tape wrap around cores if conductors are 5 or more	
内部シース / Inner sheath		—	耐油・耐熱性ビニル混合物 (黒) / Oil and heat resistant PVC (black)
シールド / Shield		—	すずめっき軟銅線編組 / Tin coated annealed copper braid
シース / Sheath		耐油・耐熱性ビニル混合物 (ライトグレー) / Oil and heat resistant PVC (light gray)	

線心識別 / Conductors identification

線心数 / No. of conductors	線心識別方式 / Conductors identification	
2心 / 2	ナンバリング No. 方式 Identification by number	黒色絶縁体上の白色ナンバリングNo. Black insulations (white ink numbering is printed on the surface of black color insulation)
3心以上 / 3 or more		黒色絶縁体上の白色ナンバリングNo.+ 緑 / 黄 Black insulations (white ink numbering is printed on the surface of black color insulation) and a green/yellow insulation

● 緑 / 黄: 緑色と黄色のストライプ (色配分 緑60 : 黄40) / Green/yellow : Green/yellow strips (by the circumference, the covered of green and yellow is 60 to 40)

例示 / Example : CE-531NZ 3 × 1mm² (18AWG)

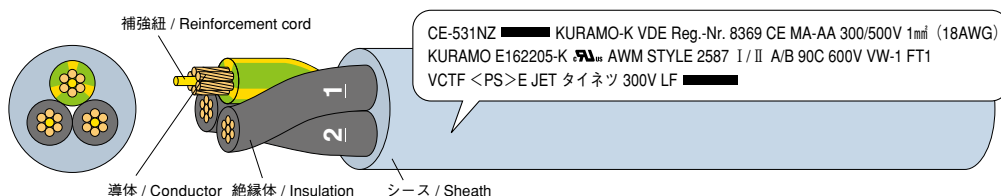

■ 構造表 / Construction table

導体 / Conductor		絶縁 / Insulation		在庫 / Stocks		シールド無し / Non-shield		シールド付き / Shield		電気特性 / Electrical characteristics		
公称断面積 Nominal cross sectional area	外径 (約mm) Diameter (Approx.mm) 構成 (Construction)	外径 (約mm) Diameter (Approx.mm)	心数 Number of conductors	シールド無 Non-shield	シールド付 Shield	シース外径 (約mm) Sheath diameter (Approx.mm)	概算重量 Approx.weight (kg/ km)	シース外径 (約mm) Sheath diameter (Approx.mm)	概算重量 Approx.weight (kg/ km)	許容電流 Allowable ampacity (A)	導体抵抗 Conductor resistance 20°C (Ω / km)	絶縁抵抗 Insulation resistance 20°C (M Ω km)
0.5mm ² <20AWG>	1.1 <6/18/0.08>	2.8	2	○		9.0	100	11.0	165	10	39.0 以下 (Max 39.0)	50 以上 (Min 50)
			3	○		9.4	110	11.5	175	9		
			4	○	○	10.5	130	12.5	205	8		
			5			11.5	145	14.0	235	7		
			6	○		12.5	165	14.5	265	7		
			7			13.0	185	15.5	295	7		
			8	○	○	14.0	215	16.5	330	7		
			10			16.0	260	18.0	390	6		
			12	○	○	15.5	265	17.5	390	6		
			15			16.5	320	19.0	475	5		
			21	○	○	19.5	430	23.5	660	5		
			25			22.0	550	24.5	750	5		
			31	○		24.0	650	27.0	880	4		
0.75mm ² <18AWG>	1.5 <6/28/0.08>	3.25	2	○		9.9	120	12.0	190	13	26.0 以下 (Max 26.0)	50 以上 (Min 50)
			3	○		10.5	140	12.5	210	11		
			4	○	○	11.5	165	13.5	250	10		
			5			12.5	180	15.0	285	9		
			6	○		13.5	210	16.0	325	9		
			7			14.5	240	17.0	360	9		
			8	○	○	15.5	270	18.0	395	8		
			10	○		18.5	345	21.0	510	8		
			12	○	○	17.5	345	20.0	495	7		
			15	○		19.0	420	23.0	660	7		
			21	○	○	23.5	630	26.0	830	6		
			25	○		24.5	710	27.0	945	6		
			31	○		27.0	850	30.0	1100	5		
1mm ² <18AWG>	1.6 <6/35/0.08>	3.4	2	○		10.5	135	12.5	205	15	19.5 以下 (Max 19.5)	50 以上 (Min 50)
			3	○		11.0	150	13.0	235	13		
			4	○	○	12.0	180	14.0	270	12		
			5			13.0	205	15.5	310	11		
			6	○		14.0	235	16.5	350	11		
			7			15.0	265	17.5	390	10		
			8	○	○	16.5	300	19.0	445	10		
			10	○		18.5	380	21.0	530	9		
			12	○	○	18.0	390	20.5	550	9		
			15			19.5	470	23.5	710	8		
			21	○	○	24.5	690	27.0	910	7		
			25	○		25.5	790	28.0	1040	7		
			31	○		28.5	960	31.5	1250	6		
1.5mm ² <16AWG>	2.05 <6/52/0.08>	3.85	2	○		11.0	160	13.5	245	20	13.3 以下 (Max 13.3)	50 以上 (Min 50)
			3	○	○	12.0	185	14.0	280	17		
			4	○	○	13.0	225	15.0	325	15		
			5			14.0	245	16.5	360	14		
			6	○		15.5	290	18.0	415	14		
			7			16.5	330	19.0	480	13		
			8	○	○	18.0	380	20.5	540	13		
			10			20.5	465	24.0	700	12		
			12	○	○	19.5	500	23.5	730	11		
			15			23.0	660	25.5	875	10		
			21	○	○	26.5	890	29.5	1130	9		
			25			28.5	1020	32.0	1330	9		
			31	○		31.5	1240	34.5	1570	8		
2.5mm ² <14AWG>	2.5 <6/86/0.08>	4.3	2	○		12.0	200	15.0	290	27	7.98 以下 (Max 7.98)	40 以上 (Min 40)
			3	○		13.0	250	15.0	335	23		
			4	○	○	14.0	290	16.0	395	21		
			5			15.5	325	18.0	455	20		
			6	○		17.0	380	19.0	520	19		
			7			18.5	440	21.0	600	18		
			8	○	○	19.5	490	23.0	720	18		
			10	○		23.5	680	26.5	890	16		
			12	○	○	23.0	720	25.5	920	15		
			15			25.0	870	28.0	1120	14		
			21	○	○	29.5	1190	32.5	1500	13		
			25	○		31.0	1370	34.5	1710	12		
			31	○		34.0	1660	37.5	2030	11		

○は在庫品です。/ ○ : Stocks

■ 許容電流について / Allowable ampacity

・許容電流値は周囲温度 30°C、空中 1 条敷設時の計算値を示し、保証値ではありません。
Allowable ampacity (A) for cable is based on calculation under aerial one-cable and temperature at 30°C , not representing a guaranteed value.

・周囲温度 30°C 以上の場合は、次の電流減少係数を表の値に掛けて下さい。
Allowable ampacity cable at ambient temperature above 30°C is to be determined by multiplying the current value by the appropriate current reduction factor in the following table1.

・許容電流の値は、JCS0168 により算出した値であって、保証値ではありません。 / The allowable ampacity for cable are the calculated by JCS0168, but not guaranteed.

〔 欧州では、建物の電気設備の配線システムの許容電流に関する規格 "IEC 60364-5-52 (Electrical installations of buildings-Part 5-52: Selection and erection of electrical equipment - Wiring systems)" がありますのでご参照下さい。
For details on Allowable ampacity of the cable when used in Europe, refer to the applicable standard "IEC 60364-5-52 (Electrical installations of buildings - Part 5-52: Selection and erection of electrical equipment - Wiring systems)" 〕

JCS0168…日本電線工業会規格 "33kV 以下電力ケーブルの許容電流計算"
"Calculation of the current rating of power cables for rated voltage up to and including 33kV"

■ 表 電流減少係数 / Table1 Current reduction factors

周囲温度 / Ambient temperature (°C)	30	35	40	45	50	55	60	65
電流減少係数 / Current reduction factors	1.00	0.94	0.87	0.79	0.71	0.61	0.5	0.35